

CARTA DE APROXIMACIÓN
POR INSTRUMENTOS-MIPS

ELEV AD
2301
VAR 0° (2020)

APP 118.730 C
278.025 MHz

TWR 122.105 C
386.675 MHz
GCA 281.075 MHz

ALBACETE
TACAN Z
RWY 27

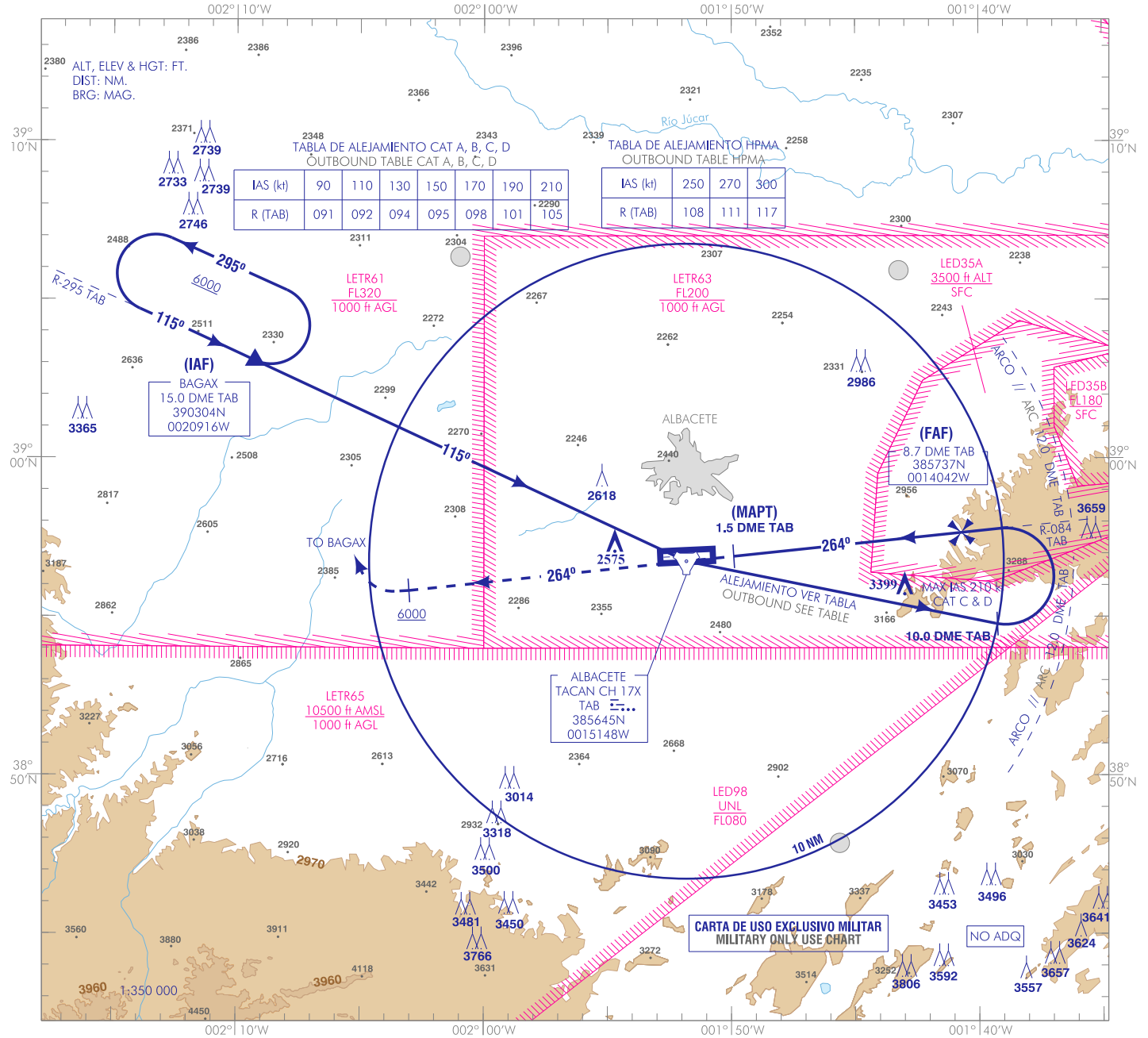

FRUSTRADA: SUBIR DIRECTO A 6000 O SUPERIOR. ESPERAR INSTRUCCIONES ATC.
FRUSTRADA FALLO DE COMUNICACIONES: SUBIR DIRECTO A 6000 O SUPERIOR. VIRAR A LA DERECHA PARA INTERCEPTAR R-295 TAB A BAGAX.
MISSED APCH: CLIMB DIRECT TO 6000 OR ABOVE. WAIT FOR ATC INSTRUCTIONS.
MISSED APCH COMMUNICATIONS FAILURE: CLIMB DIRECT TO 6000 OR ABOVE. TURN RIGHT TO INTERCEPT R-295 TAB TO BAGAX.

- NOTAS:
 - NO VIRAR ANTES DEL MAPT.
 - NO SOBREVOLAR ARCO 12.0 DME TAB.
 NOTES:
 - DO NOT TURN BEFORE MAPT.
 - DO NOT OVERFLY ARC 12.0 DME TAB.

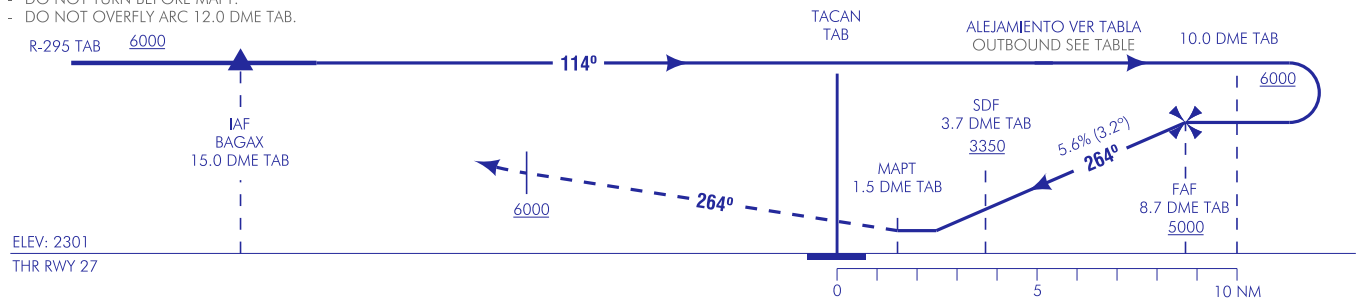

HGT REF ELEV THR RWY 27

| CAT | A | B | C | D | HPMA |
|--------------------------|------------------------------|------------------------------|------------------------------|------------------------------|------------------------------|
| S-TACAN | 2690/1.5 390 (400-1.5) | | | 2690/1.8 390 (400-1.8) | |
| CIRCUITO CIRCLING | 2700/1.5 400 (400-1.5) | 2800/1.6 500 (500-1.6) | 3150/2.4 850 (900-2.4) | 3150/3.6 850 (900-3.6) | 2920/3.2 620 (700-3.2) |

| GS | kt | 80 | 100 | 120 | 140 | 160 | 180 |
|------------------|--------|--|-----|-----|-----|-----|------|
| FAF-THR: | min:s | | | | | | |
| FAF-MAPT: | min:s | NO AUTORIZADO EL CRONOMETRAJE // TIMING NOT AUTHORIZED | | | | | |
| ROD: 5.6% | ft/min | 450 | 562 | 635 | 787 | 899 | 1012 |

| ALT DME (TAB) FNA | | | | | | | | | | | |
|-------------------|----|----|----|---|------|------|------|------|------|------|------|
| 13 | 12 | 11 | 10 | 9 | 8 | 7 | 6 | 5 | 4 | 3 | |
| | | | | | 4820 | 4480 | 4140 | 3810 | 3470 | 3130 | 2800 |

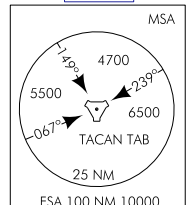

CAMBIOS: FRECUENCIAS, AERÓDROMOS RESTRINGIDOS, OBSTÁCULOS.
CHANGES: FRECUENCIAS, RESTRICTED AERODROMES, OBSTACLES.

INTENCIONADAMENTE EN BLANCO
INTENTIONALLY BLANK