

PLANO DE OBSTÁCULOS DE AERÓDROMO - OACI  
TIPO A (LIMITACIONES DE UTILIZACIÓN)

LOGROÑO  
RWY 11

ELEV. DIM: M.

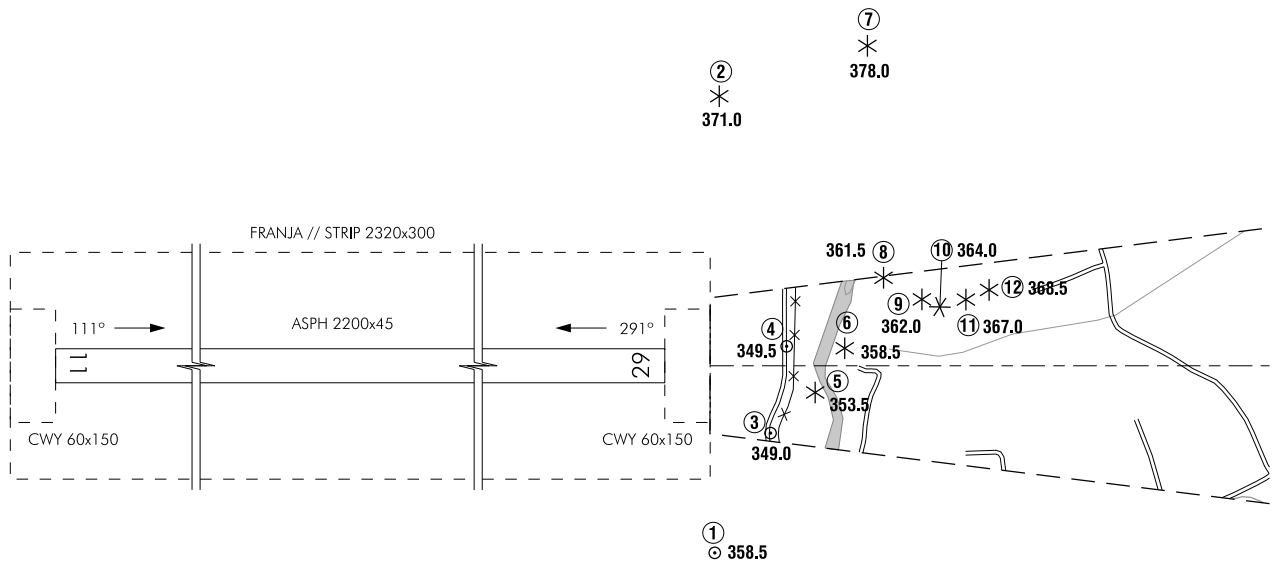
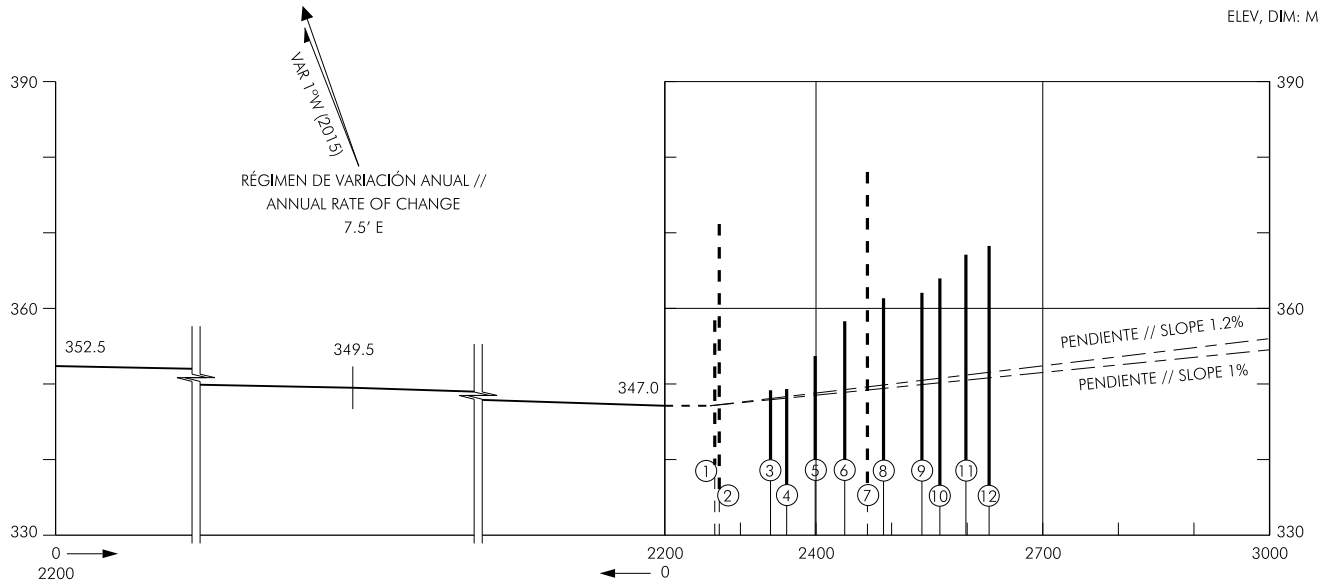

ORDEN DE EXACTITUD // ORDER OF ACCURACY  
VERTICAL: 0.5 m  
HORIZONTAL: 5 m

CLAVE // LEGEND

Árbol o Arbusto // Tree or Shrub	*
Carretera // Road	==
Cota de terreno // Spot elevation	•
Curva de nivel del Terreno // Terrain Contour Line	~
Edificio o estructura grande // Building or large structure	■
Vallado // Fence	-x-x-
Ferrocarril // Railroad	+ + +
Línea de Transmisión o Cable Aéreo // Transmission Line or Overhead Cable	- T - T -
Obstáculo móvil // Mobile obstacle	- - - - -
Poste, Torre, Campanario, Antena, etc. // Pole, Tower, Spire, Antenna, etc.	⊙
Terrano que penetra el plano de obstáculos // Terrain penetrating obstacle plane	⬆

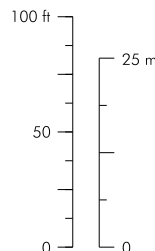

ESCALA VERTICAL // VERTICAL SCALE  
1:1 000

ESCALA HORIZONTAL // HORIZONTAL SCALE  
1:10 000

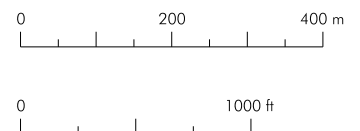

DISTANCIAS DECLARADAS // DECLARED DISTANCES

RWY 11		RWY 29	
2200	TORA	2200	
2260	TODA	2260	
2200	ASDA	2200	
2200	LDA	2200	

IDENT

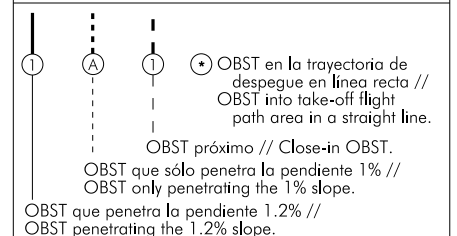

CAMBIOS: NUEVO ESTUDIO DE OBSTACULOS. // CHANGES: NEW OBSTACLE SURVEY.

**INTENCIONADAMENTE EN BLANCO**  
**INTENTIONALLY BLANK**