

PLANO DE OBSTÁCULOS DE AERÓDROMO OACI
TIPO A (LIMITACIONES DE UTILIZACIÓN)

GIRONA
RWY 01

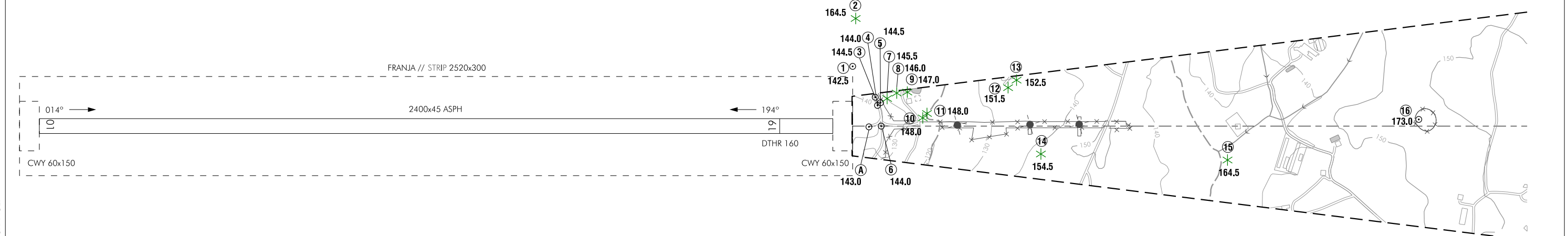
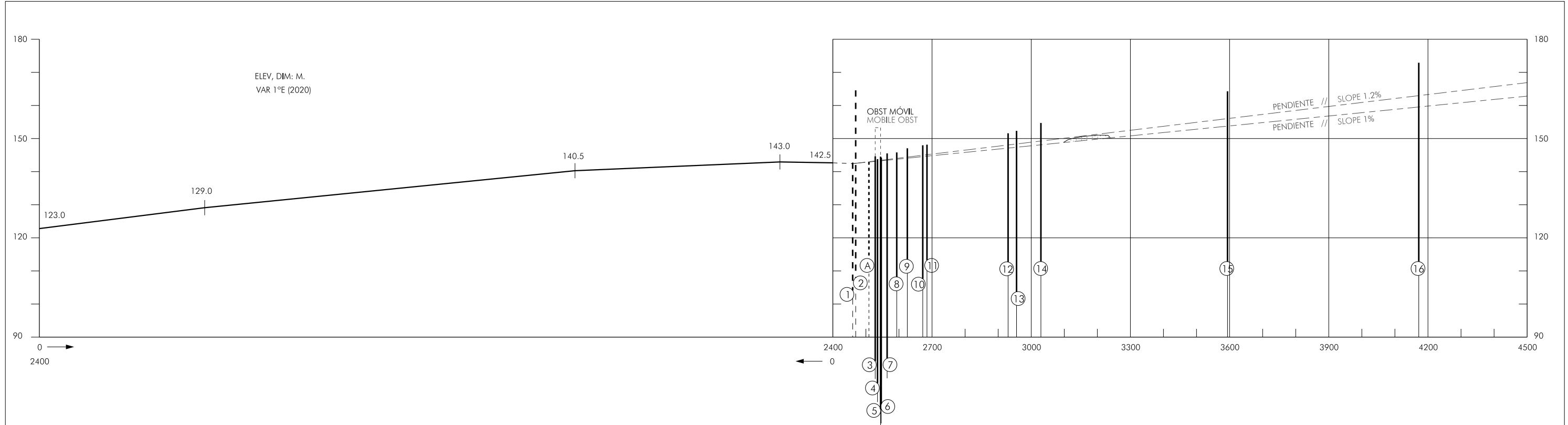

ORDEN DE EXACTITUD
ORDER OF ACCURACY
VERTICAL: 0.5 m
HORIZONTAL: 5 m

NOTA: ESTUDIO DE OBSTÁCULOS DE DICIEMBRE DE 2017.
NOTE: OBSTACLE SURVEY DECEMBER 2017.

CAMBIOS: VARIACIÓN MAGNÉTICA, RUMBOS DE RWY, DESIGNADOR DE RWY, RÉGIMEN DE VARIACIÓN ANUAL.
CHANGES: MAGNETIC VARIATION, RWY HEADINGS, RWY DESIGNATOR, ANNUAL RATE OF CHANGE.

Árbol o Arbusto Tree or Shrub	*
Carretera Road	==
Cota de terreno Spot elevation	•
Curva de nivel del Terreno Terrain Contour Line	~
Edificio o estructura grande Building or large structure	■
Vallado Fence	-x-x-
Ferrocarril Railroad	++
Línea de Transmisión o Cable Aéreo Transmission Line or Overhead Cable	-T-T-
Obstáculo móvil Mobile obstacle	- - - - -
Poste, Torre, Campanario, Antena, etc. Pole, Tower, Spire, Antenna, etc.	⊙
Terreno que penetra el plano de obstáculos. Terrain penetrating obstacle plane.	▲

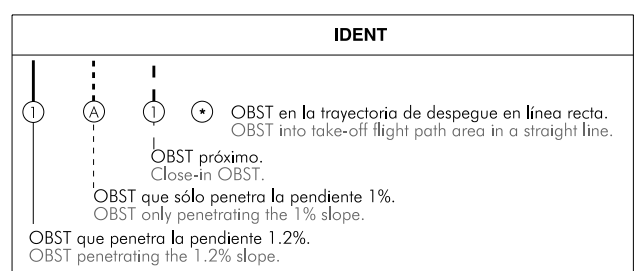

**DISTANCIAS DECLARADAS
DECLARED DISTANCES**

RWY 01		RWY 19
2400	TORA	2400
2460	TODA	2460
2400	ASDA	2400
2400	LDA	2240

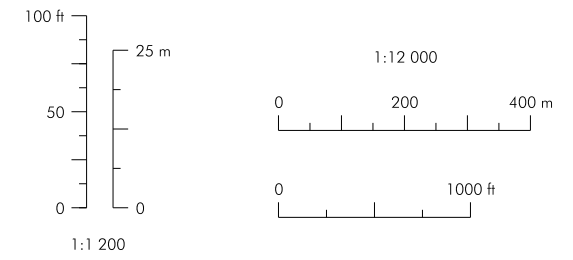

INTENCIONADAMENTE EN BLANCO
INTENTIONALLY BLANK